

METRİK NORMAL DİŞ PAFTA 6g HSS (950)				NB-223M	NB-223ML SOL
d	P	D	E	FİYAT KODU	FİYAT KODU
M2	0,4	16	5	07876	07903
M2,5	0,45	16	5	07877	07904
M3	0,5	20	5	07878	07905
M3,5	0,6	20	5	07879	07906
M4	0,7	20	5	07880	07907
M4,5	0,75	20	7	07881	07908
M5	0,8	20	7	07882	07909
M6	1	20	7	07883	07910
M7	1	25	9	07884	07911
M8	1,25	25	9	07885	07912
M9	1,25	25	9	07886	07913
M10	1,5	30	11	07887	07914
M11	1,5	30	11	07888	07915
M12	1,75	38	14	07889	07916
M14	2	38	14	07890	07917
M16	2	45	18	07891	07918
M18	2,5	45	18	07892	07919
M20	2,5	45	18	07893	07920
M22	2,5	55	22	07894	07921
M24	3	55	22	07895	07922
M27	3	65	25	07896	07923
M30	3,5	65	25	07897	07924
M33	3,5	65	25	07898	07925
M36	4	65	25	07899	07926
M39	4	75	30	07900	07927
M42	4,5	75	30	07901	07928
M45	4,5	90	36	07902	07929
Yüksek hız çeliği				KULLANIM ALANI El ve makinalarda kullanmaya uygundur. Eğik ağız bileme özelliği ile temiz vida elde edilir. Tüm çelik türlerinde kullanıma uygundur.	El ve makinalarda kullanmaya uygundur. Eğik ağız bileme özelliği ile temiz vida elde edilir. Tüm çelik türlerinde kullanıma uygundur. Sol diş açma işleminde kullanılır.

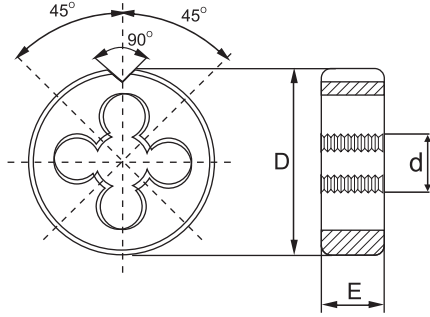
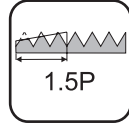
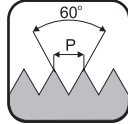

METRİK İNCE DİŞ PAFTA 6g HSS (950)				NB-223M	NB-223ML SOL
d	P	D	E	FİYAT KODU	FİYAT KODU
M4	0,5	20	5	07930	07960
M4,5	0,5	20	5	07931	07961
M5	0,5	20	5	07932	07962
M5,5	0,5	20	5	07933	07963
M6	0,75	20	7	07934	07964
M6	0,5	20	7	07935	07965
M7	0,75	25	9	07936	07966
M8	1	25	9	07937	07967
M8	0,75	25	9	07938	07968
M8	0,5	25	9	07939	07969
M9	1	25	9	07940	07970
M9	0,75	25	9	07941	07971
M10	1,25	30	11	07942	07972
M10	1	30	11	07943	07973
M10	0,75	30	11	07944	07974
M11	1	30	11	07945	07975
M12	1,5	38	10	07946	07976
M12	1,25	38	10	07947	07977
M12	1	38	10	07948	07978
M14	1,5	38	10	07949	07979
M14	1,25	38	10	07950	07980
M14	1	38	10	07951	07981
M15	1,5	38	10	07952	07982
M15	1	38	10	07953	07983
M16	1,5	45	14	07954	07984
M16	1	45	14	07955	07985
M17	1,5	45	14	07956	07986
M17	1	45	14	07957	07987
M18	2	45	14	07958	07988
M18	1,5	45	14	07959	07989

HSS → Yüksek hız çeliği

KULLANIM ALANI

El ve makinalarda kullanmaya uygundur. Eğik ağız bileme özelliği ile temiz vida elde edilir. Tüm çelik türlerinde kullanıma uygundur.

El ve makinalarda kullanmaya uygundur. Eğik ağız bileme özelliği ile temiz vida elde edilir. Tüm çelik türlerinde kullanıma uygundur. Sol diş açma işleminde kullanılır.

MF

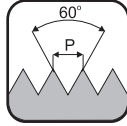

HSS

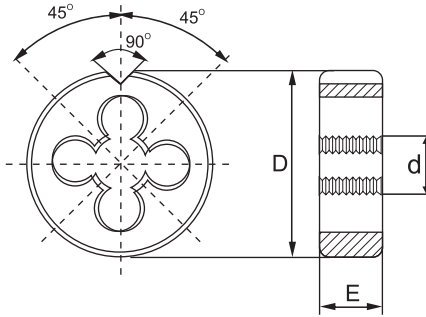
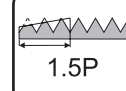
DIN
223

METRİK İNCE DİŞ PAFTA 6g HSS (950)

NB-223M

NB-223ML SOL

d	P	D	E	FİYAT KODU	FİYAT KODU
M18	1	45	14	07990	08020
M20	2	45	14	07991	08021
M20	1,5	45	14	07992	08022
M20	1	45	13	07993	08023
M22	2	55	16	07994	08024
M22	1,5	55	16	07995	08025
M22	1	55	15	07996	08026
M24	2	55	16	07997	08027
M24	1,5	55	16	07998	08028
M25	1,5	55	16	07999	08029
M26	1,5	55	16	08000	08030
M27	2	65	18	08001	08031
M27	1,5	65	18	08002	08032
M27	1	65	18	08003	08033
M28	2	65	18	08004	08034
M28	1,5	65	18	08005	08035
M30	3	65	25	08006	08036
M30	2	65	18	08007	08037
M30	1,5	65	18	08008	08038
M30	1	65	18	08009	08039
M32	1,5	65	18	08010	08040
M33	2	65	18	08011	08041
M33	1,5	65	18	08012	08042
M35	1,5	65	18	08013	08043
M36	3	65	25	08014	08044
M36	2	65	18	08015	08045
M36	1,5	65	18	08016	08046
M39	3	75	30	08017	08047
M39	2	75	20	08018	08048
M39	1,5	75	20	08019	08049

HSS

→ Yüksek hız çeliği

KULLANIM ALANI

El ve makinalarda kullanmaya uygundur. Eğik ağız bileme özelliği ile temiz vida elde edilir. Tüm çelik türlerinde kullanıma uygundur.

El ve makinalarda kullanmaya uygundur. Eğik ağız bileme özelliği ile temiz vida elde edilir. Tüm çelik türlerinde kullanıma uygundur. Sol diş açma işleminde kullanılır.

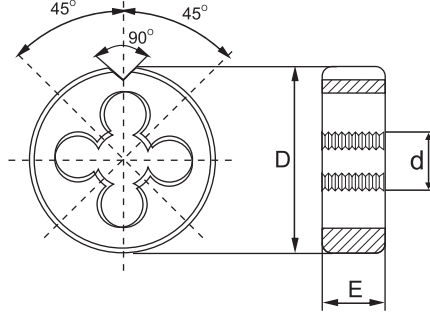
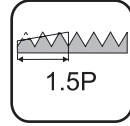
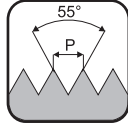

GAZ DIŞ PAFTA 6g HSS (9502)				NB-223G
d	P	D	E	FİYAT KODU
G 1/16	28	25	9	08050
G 1/8	28	30	11	08051
G 1/4	19	38	10	08052
G 3/8	19	45	14	08053
G 1/2	14	45	14	08054
G 5/8	14	55	16	08055
G 3/4	14	55	16	08056
G 7/8	14	65	18	08057
G 1	11	65	18	08058
G 1 1/8	11	75	20	08059
G 1 1/4	11	75	20	08060
G 1 3/8	11	90	22	08061
G 1 1/2	11	90	22	08062
G 1 3/4	11	105	22	08063
G 2	11	105	22	08064
→ Yüksek hız çeliği				<p>KULLANIM ALANI</p> <p>El ve makinalarda kullanmaya uygundur. Eğik ağız bileme özelliği ile temiz vida elde edilir. Tüm çelik türlerinde kullanıma uygundur.</p>

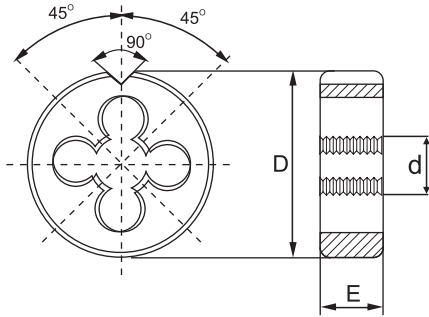
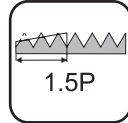
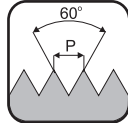

UNF PAFTA 6g HSS (9505)				NB-223UNF
d	P	D	E	FİYAT KODU
UNF NR5	44	20	5	08065
UNF NR6	40	20	5	08066
UNF NR8	36	20	7	08067
UNF NR10	32	20	7	08068
UNF NR12	28	20	7	08069
UNF 1/4	28	20	7	08070
UNF 5/16	24	25	9	08071
UNF 3/8	24	30	11	08072
UNF 7/16	20	30	11	08073
UNF 1/2	20	38	10	08074
UNF 9/16	18	38	10	08075
UNF 5/8	18	45	14	08076
UNF 3/4	16	45	14	08077
UNF 7/8	14	55	16	08078
UNF 1	12	55	16	08079
→ Yüksek hız çeliği			KULLANIM ALANI	El ve makinalarda kullanmaya uygundur. Eğik ağız bileme özelliği ile temiz vida elde edilir. Tüm çelik türlerinde kullanıma uygundur.

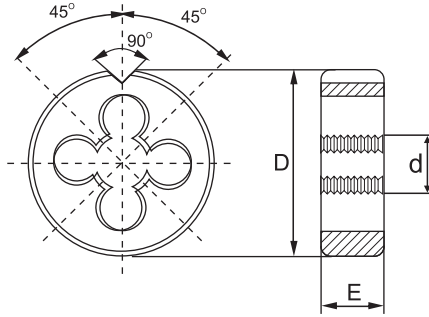
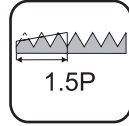
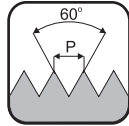

UNC PAFTA 6g HSS (9505)				NB-223UNC
d	P	D	E	FİYAT KODU
UNC NR5	40	20	5	08080
UNC NR6	32	20	7	08081
UNC NR8	32	20	7	08082
UNC NR10	24	20	7	08083
UNC NR12	24	20	7	08084
UNC 1/4	20	20	7	08085
UNC 5/16	18	25	9	08086
UNC 3/8	16	30	11	08087
UNC 7/16	14	30	11	08088
UNC 1/2	13	38	14	08089
UNC 9/16	12	38	14	08090
UNC 5/8	11	45	18	08091
UNC 3/4	10	45	18	08092
UNC 7/8	9	55	22	08093
UNC 1	8	55	22	08094

HSS → Yüksek hız çeliği

KULLANIM ALANI

El ve makinalarda kullanmaya uygundur. Eğik ağız bileme özelliği ile temiz vida elde edilir. Tüm çelik türlerinde kullanıma uygundur.

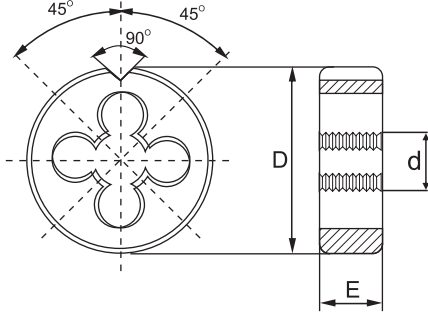

WHITHWORTH PAFTA 6g HSS (9501)				NB-223W
d	P	D	E	FİYAT KODU
W 1/8	40	20	5	08095
W 5/32	32	20	5	08096
W 3/16	24	20	7	08097
W 1/4	20	20	7	08098
W 5/16	18	25	9	08099
W 3/8	16	20	11	08100
W 7/16	14	30	11	08101
W 1/2	12	38	14	08102
W 9/16	12	38	14	08103
W 5/8	11	45	18	08104
W 3/4	10	45	18	08105
W 7/8	9	55	22	08106
W 1	8	55	22	08107

HSS → Yüksek hız çeliği

KULLANIM ALANI

El ve makinalarda kullanmaya uygundur. Eğik ağız bileme özelliği ile temiz vida elde edilir. Tüm çelik türlerinde kullanıma uygundur.